

(No Model.)

A. MERCER.
TOOL HOLDER.

No. 296,989.

Patented Apr. 15, 1884.

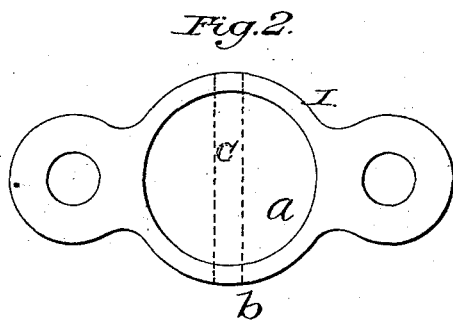
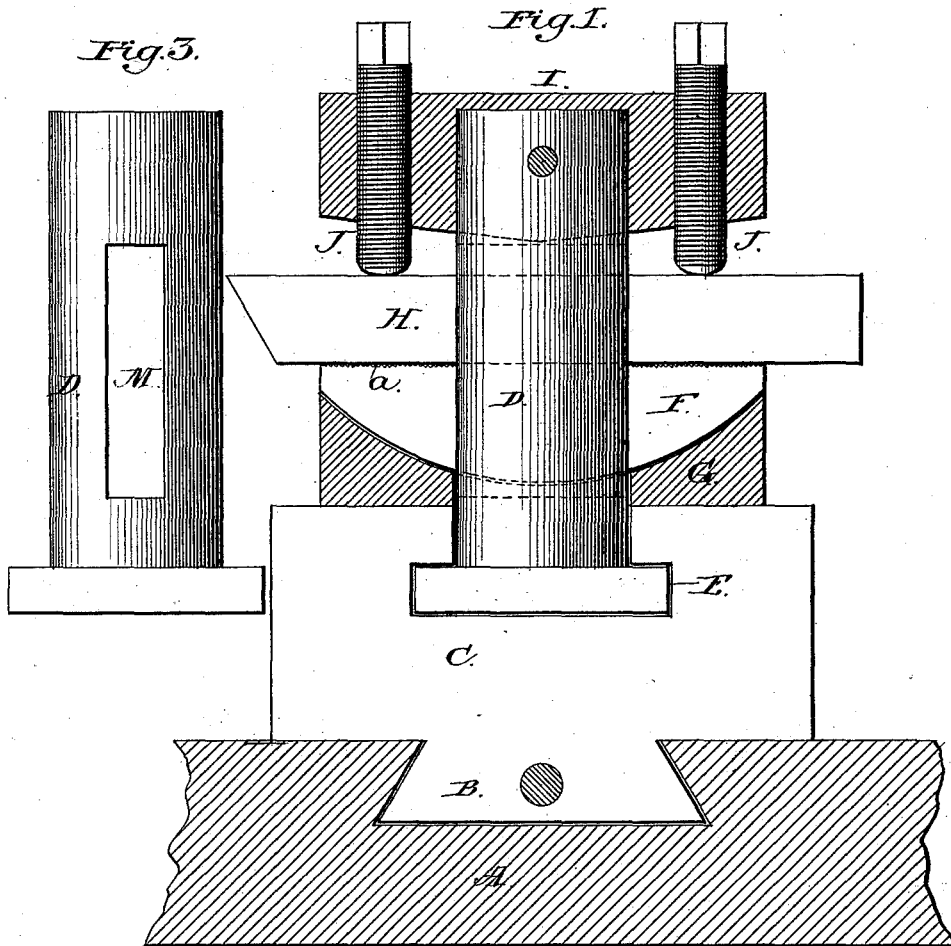

WITNESSES
John A. Ellis.
Philip C. Masi.

INVENTOR
Alfonso Mercer,
by Anderson & Smith
his ATTORNEYS

UNITED STATES PATENT OFFICE.

ALFONSO MERCER, OF NORFOLK, VA., ASSIGNOR OF ONE-HALF TO WILLIAM SANDERLIN AND THOMAS M. SANDERLIN, BOTH OF SAME PLACE.

TOOL-HOLDER.

SPECIFICATION forming part of Letters Patent No. 296,989, dated April 15, 1884.

Application filed September 27, 1881. (No model.)

To all whom it may concern:

Be it known that I, ALFONSO MERCER, a citizen of the United States, residing at Norfolk, in the county of Norfolk and State of Virginia, have invented certain new and useful Improvements in Tool-Holders for Lathes and Planers; and I do hereby declare the following to be a full, clear, and exact description of the invention, such as will enable others skilled in the art to which it appertains to make and use the same, reference being had to the accompanying drawings, and to letters or figures of reference marked thereon, which form a part of this specification, in which—

Figure 1 is a vertical section, partly in elevation. Fig. 2 is a bottom view of the head-plate. Fig. 3 is a side view of the tool-post.

This invention has relation to improvements in tool-holders for lathes and planers; and it consists in the construction and novel arrangement of parts, as will be hereinafter more fully set forth, and particularly pointed out in the claim appended.

Referring by letter to the accompanying drawings, A designates the bed-plate, B the tongue fitting the groove in the same, and C the tool-seat, which are of the ordinary construction.

The cylindrical tool-post D has a flattened flanged base, which slides into the way E of the tool-seat, and is provided with a slot, M, to receive a plano-convex key, F, which has its plane side roughened, to prevent the tool which bears thereon from slipping during operation.

G indicates a concavo-plano washer, which is placed over the cylindrical tool-post, and has its bearing on the tool-seat C, the convex surface of the key F engaging and having its bearing at all times in the convex face of the washer. By this construction it will be seen

that the washer cannot slip or play upon the tool-seat as it is held by the tool-post, but will always form a rigid concavo bearing for the key. The tool H rests upon the plano surface of the key F, which has a file or roughened surface, to prevent the tool from slipping. The upper surface of the cutting-tool is of soft iron, in order that the binding-screws may bite thereon.

I indicates the head-block, which is provided on its under side with a central annular recess, a, to receive the upper end of the tool-post, and transversely of the block through the walls of the said recess is a perforation, b, to receive a cylindrical or other suitable key, c, for locking the head-block to the tool-post, as shown. This head-block is provided with perforations for the usual binding-screws, J J, and is beveled on its under side from its center outwardly and upwardly in opposite directions, so as to allow the tool to be adjusted and held by the binding-screws at a greater or less angle, as desired.

I am aware that it is not new to provide a concave bearing for tools, whereby they may be held at different inclinations in a lathe or planer by means of binding-screws, and therefore do not claim such construction, broadly; but

What I claim as new, and desire to secure by Letters Patent, is—

The head-block I, fast to the head of the tool-post, jointly with the binding-screws J, for clamping the tool, substantially as specified.

In testimony whereof I affix my signature in presence of two witnesses.

ALFONSO MERCER.

Witnesses:

THEO. MUNGEN,
PHILIP C. MASI.